

特性 FEATURES

- 具有一组常开触点形式
- 30A 触点切换能力
- 工作温度高达 125℃
- 外形尺寸: 27.3 × 23 × 29.4mm

- 1 form A contact arrangement
- 30A switching capability
- Ambient temp can up to 125℃
- Outline dimensions: 27.3 × 23 × 29.4 mm

触点参数 CONTACT PARAMETERS

触点形式	Contact Arrangement	1A
触点材料	Contact Material	银合金 Silver Alloy
接触压降 (初始)	Voltage Drop(Initial)	典型值 Typ. 50mV, 最大值 Max. 300mV (at 10A)
最大连续电流	Max. Continuous Current	27A
最大切换电压	Max. Switching Voltage	30VDC
电气寿命	Electrical Life	1 × 10 ⁵ 次 OPS
机械寿命	Mechanical Life	1 × 10 ⁶ 次 OPS

性能参数 FUNCTION PARAMETERS

绝缘电阻	Insulation Resistance	500MΩ (500VDC)
介质耐压	Dielectric Strength	触点与线圈间 Between Coil & Contacts: 500VAC 1min
		断开触点间 Between Open Contacts: 500VAC 1min
动作时间	Operate Time	≤7ms
释放时间	Release Time	≤5ms
环境温度	Ambient Temperature	-40℃ ~+125℃
振动	Vibration	10Hz~500Hz 49m/s ²
冲击	Shock	147m/s ²
引出端方式	Terminal Form	快速接式引出端 QC
封装形式	Construction	防尘罩型 Dust Protected
重量	Unit Weight	约 Approx. 34g
机械性能	Mechanical Data	外壳保持力: (拉和压) 200N Cover Retention: (Pull & Push) 200N
		引出脚保持力: (拉和压) 100N Terminal Retention: (Pull & Push) 100N
		引出脚抗弯曲力: (各方向) 10N Terminal Resistance To Bending: (Front & Side) 10N

线圈规格表 COIL DATA(23℃)

额定电压 Rated Voltage VDC	动作电压 Operate Voltage VDC	释放电压 Release Voltage VDC	线圈电阻 Coil Resistance Ω ± 10%	线圈功率 Coil Power W	允许最大线圈电压 ⁽¹⁾ Max Allowable Overdrive Voltage VDC	
					20℃	85℃
6	≤4.2	≥0.6	25	1.44	13.2	7.8
12	≤8.4	≥1.2	100		26	16
24	≤16.8	≥2.4	400		48.6	30

注意: (1) 触点无负载电流、线圈电阻为最小值情况下, 继电器线圈允许施加的最大连续工作电压。
 Note: (1) Max. Allowable overdrive voltage is stated with no load applied minimum coil resistance.

订货标记示例 ORDERING INFORMATION

			MAV	-1	12	-A	-1	-R
产品型号	Model:	MAV						
触点组数	Contact Group:	1: 1组 1 Group						
线圈电压	Coil Voltage:	06、12、24 VDC						
触点形式	Contact Form:	A: 常开 NO						
结构形式	Structure Style	1: 光背快速接引出端 Cover Without Bracket						
		2: 铁背快速接引出端 Cover With Metal Bracket						
		3: 塑背快速接引出端 Cover With Plastic Bracket						
线圈并联电阻	Coil Derived Resistance:	无 Nil: 无并联原件 Without parallel components						
		R: 并联电阻 With Resistor						
		D1: 并联二极管 (阳极接#2) With Parallel Diode (Anode on 2)						
		D2: 并联二极管 (阳极接#1) With Parallel Diode (Anode on 1)						

外形尺寸、接线图、安装孔尺寸 OUTLINE DIMENSIONS, WIRING DIAGRAM AND PCB LAYOUT(单位 Unit: mm)

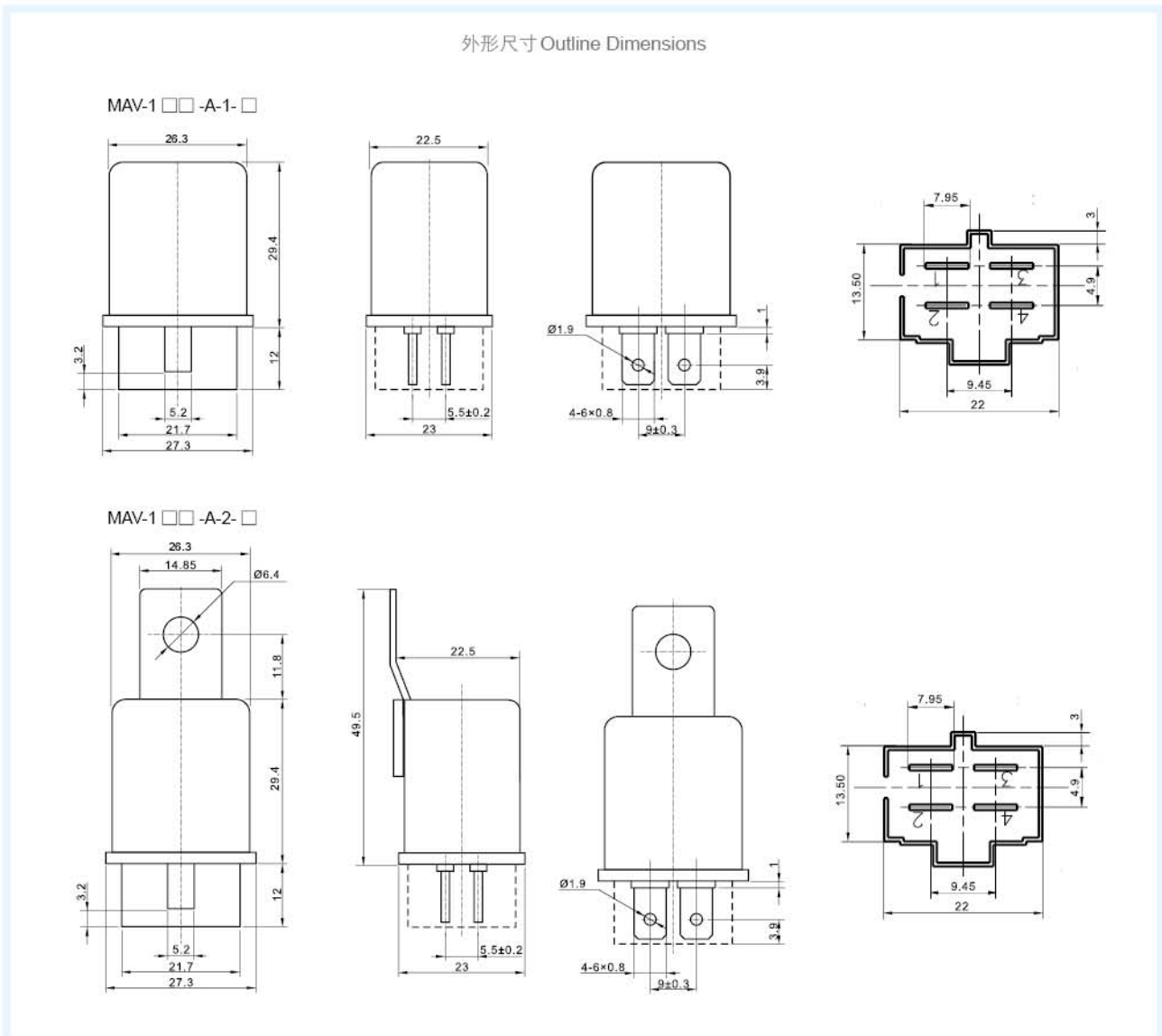

外形尺寸 Outline Dimensions

MAV-1 □□ -A-3- □

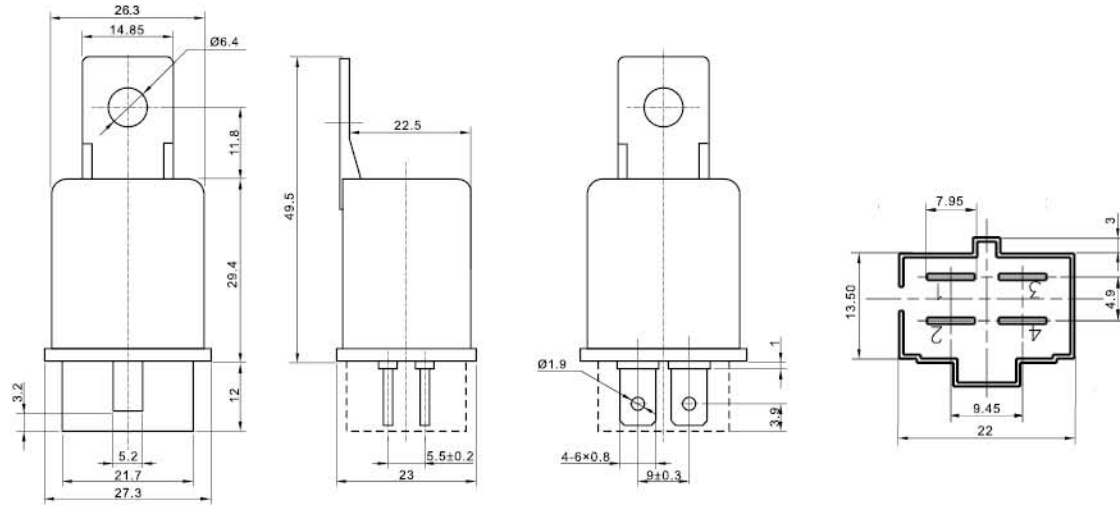

接线图 Wiring Diagram

MAV-1 □□ -A- □

MAV-1 □□ -A- □ -R

MAV-1 □□ -A- □ -D1

MAV-1 □□ -A- □ -D2

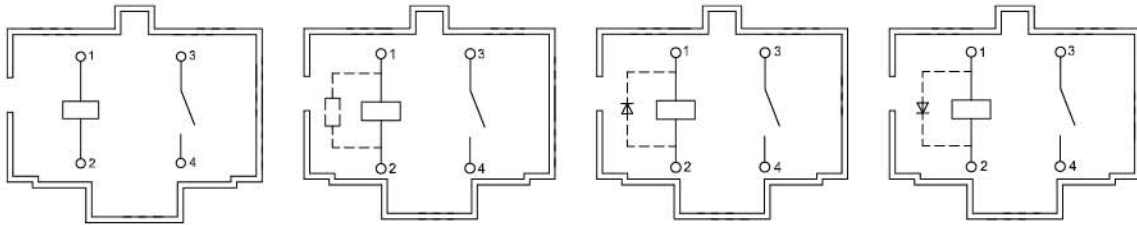

备注:

 (1) 产品部分外形尺寸未注尺寸公差, 当外形尺寸 $\leq 1\text{mm}$, 公差为 $\pm 0.2\text{mm}$; 当外形尺寸在 $1\sim 5\text{mm}$ 之间时, 公差为 $\pm 0.3\text{mm}$; 当外形尺寸 $> 5\text{mm}$ 时, 公差为 $\pm 0.4\text{mm}$;
 (2) 安装孔尺寸中未注尺寸公差的均为 $\pm 0.1\text{mm}$ 。

REMARK:

 (1) In case of no tolerance shown in outline dimension: outline dimension $\leq 1\text{mm}$, tolerance should be $\pm 0.2\text{mm}$; outline dimension $> 1\text{mm}$ and $\leq 5\text{mm}$, tolerance should be $\pm 0.3\text{mm}$;
 outline dimension $> 5\text{mm}$, tolerance should be $\pm 0.4\text{mm}$;
 (2) The tolerance without indicating for PCB layout is always $\pm 0.1\text{mm}$.

声明 STATEMENT:

本产品规格书仅供客户使用时参考, 若有更改, 恕不另行通知。

客户应根据具体的使用条件选择与之相匹配的产品。若有疑问, 请与美硕联系获取更多的技术支持, 但产品选型责任由客户承担。

This product specification is for reference only to customers, subject to change without notice.

The customer should select the matching product according to the use condition. Any questions, please feel free contact us to get more technical support. However, product selection responsibility only by the customer.

© Copyright Zhejiang MEISHUO Electric Technology Co.,Ltd. All right reserved.