

特性 FEATURES

- 30A 触点切换能力
 - 工作温度高达 125℃
 - 具有一组常开、一组转换触点形式
 - 防尘罩和塑封型可供选择
 - 外形尺寸: 20.1 × 15.1 × 22.2mm
-
- 30A switching capability
 - Ambient temp can reach 125℃
 - 1 form A & 1 form C contact arrangement
 - Dust protected type and sealed type available
 - Outline dimensions: 20.1 × 15.1 × 22.2mm

触点参数 CONTACT PARAMETERS

触点形式	Contact Arrangement	1A, 1C
触点材料	Contact Material	银合金 Silver Alloy
接触压降 (初始)	Voltage Drop(Initial)	NO: 典型值 Typ. 15mV, 最大值 Max. 300mV (at 10A)
		NC: 典型值 Typ. 25mV, 最大值 Max. 300mV (at 10A)
最大连续电流	Max. Continuous Current	NO: 30A
		NC: 20A
最大切换电压	Max. Switching Voltage	40VDC
电气寿命	Electrical Life	见附表 1 See schedule 1
机械寿命	Mechanical Life	1 × 10 ⁶ 次 OPS

附表 1 SCHEDULE 1

负载电压 Load Voltage	负载类型 Load Type		触点负载电流 Load Current A			通断比 On/Off Ratio		电耐久性 (次) Electrical Endurance OPS	试验环境温度 Ambient Temp.
			1C		1A	接通 On s	断开 Off s		
			常开 NO	常闭 NC	常开 NO				
14VDC	阻性 Resistive	接通 Make	20	10	30	2	2	1 × 10 ⁵	详见电耐久性 试验环境温度 曲线 See Ambient Temp. Curve
		断开 Break	20	10	30	2	2	1 × 10 ⁵	
	感性 Flasher	接通 Make	40	20	40	2	2	1 × 10 ⁵	
		断开 Break	20	10	20	2	2	1 × 10 ⁵	
	灯 Lamp	接通 Make	100	-	100	2	2	1 × 10 ⁵	
		断开 Break	20	-	20	2	2	1 × 10 ⁵	
27VDC	阻性 Resistive	接通 Make	20	10	20	2	2	1 × 10 ⁵	
		断开 Break	20	10	20	2	2	1 × 10 ⁵	
	感性 Flasher	接通 Make	38	28	38	2	2	1 × 10 ⁵	
		断开 Break	15	6	15	2	2	1 × 10 ⁵	
	灯 Lamp	接通 Make	70	-	70	2	2	1 × 10 ⁵	
		断开 Break	7	-	7	2	2	1 × 10 ⁵	

性能参数 FUNCTION PARAMETERS

绝缘电阻	Insulation Resistance	500MΩ (500VDC)
介质耐压	Dielectric Strength	触点与线圈间 Between Coil & Contacts: 500VAC 1min
		断开触点间 Between Open Contacts: 500VAC 1min
动作时间	Operate Time	≤20ms
释放时间	Release Time	≤10ms
环境温度	Ambient Temperature	-40℃ ~+125℃
振动	Vibration	10Hz~500Hz 49m/s ² (5G)
冲击	Shock	196m/s ² (20G)
引出端方式	Terminal Form	快速接式引出端 QC
封装形式	Construction	防尘罩型 Dust Protected、塑封型 Sealed
重量	Unit Weight	约 Approx.: 22g
机械性能	Mechanical Data	外壳保持力:(拉和压)200N Cover Retention: (Pull & Push) (200N)
		引出脚保持力:(拉和压)100N Terminal Retention: (Pull & Push)100N
		引出脚抗弯曲力:(各方向)10N Terminal Resistance To Bending: (Front & Side)10N

线圈规格表 COIL DATA(23℃)

额定电压 Rated Voltage VDC	动作电压 Operate Voltage VDC	释放电压 Release Voltage VDC	线圈电阻 Coil Resistance Ω ± 10%	线圈功率 Coil Power W	并联电阻 Parallel Resistance Ω ± 10%	等效电阻 Equivalent Resistance Ω ± 10%	允许最大线圈电压 ⁽¹⁾ Max Allowable Overdrive Voltage VDC	
							20℃	85℃
12	≤8.4	≥1.2	90	1.6	-	-	20	15
12	≤8.4	≥1.2	90	1.8	680	79.5	20	15
24	≤16.8	≥2.4	360	1.6	-	-	40	30
24	≤16.8	≥2.4	360	1.8	2700	317.6	40	30

注意:(1)触点无负载电流、线圈电阻为最小值情况下,继电器线圈允许施加的最大连续工作电压。

Note: Max. Allowable overdrive voltage is stated with no load applied minimum coil resistance.

订货标记示例 ORDERING INFORMATION

				MAA2	-S	-1	12	-C	-R
产品型号	Model:	MAA2							
产品结构	Structure:	无 Nil: 防尘罩型 Dust Protected S: 塑封型 Sealed							
触点组数	Contact Group:	1: 1组 1 Group							
线圈电压	Coil Voltage:	12:12VDC 24:24VDC							
触点形式	Contact Form:	A: 常开 NO C: 转换 NO/NC 无 Nil: 无并联原件 Without parallel components R: 并联电阻 With Resistor							
线圈并联元件	Parallel Coil Components:	D1: 并联二极管 (阳极接 #86)With Parallel Diode (Anode on 86) D2: 并联二极管 (阳极接 #85)With Parallel Diode (Anode on 85)							

外形尺寸、接线图、安装孔尺寸 OUTLINE DIMENSIONS, WIRING DIAGRAM AND PCB LAYOUT (单位 Unit: mm)

外形尺寸 Outline Dimensions

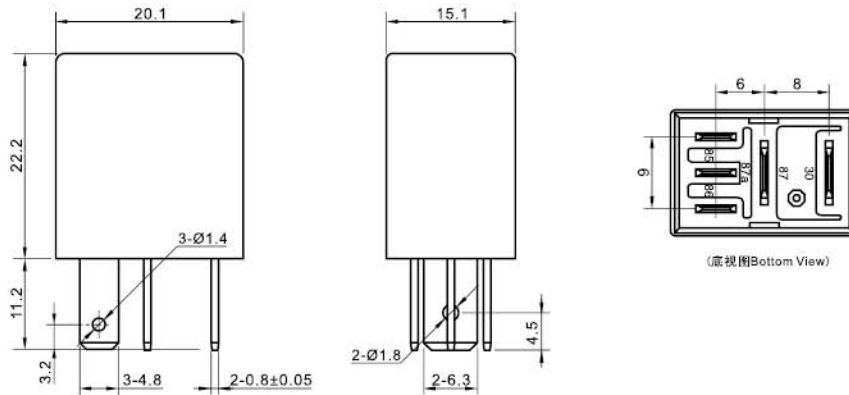

备注:

 (1) 产品部分外形尺寸未注尺寸公差, 当外形尺寸 $\leq 1\text{mm}$, 公差为 $\pm 0.2\text{mm}$; 当外形尺寸在 $1\sim 5\text{mm}$ 之间时, 公差为 $\pm 0.3\text{mm}$; 当外形尺寸 $> 5\text{mm}$ 时, 公差为 $\pm 0.4\text{mm}$;

REMARK:

 (1) In case of no tolerance shown in outline dimension: outline dimension $\leq 1\text{mm}$, tolerance should be $\pm 0.2\text{mm}$; outline dimension $> 1\text{mm}$ and $\leq 5\text{mm}$, tolerance should be $\pm 0.3\text{mm}$; outline dimension $> 5\text{mm}$, tolerance should be $\pm 0.4\text{mm}$;

接线图 Wiring Diagram (底视图 Bottom View)

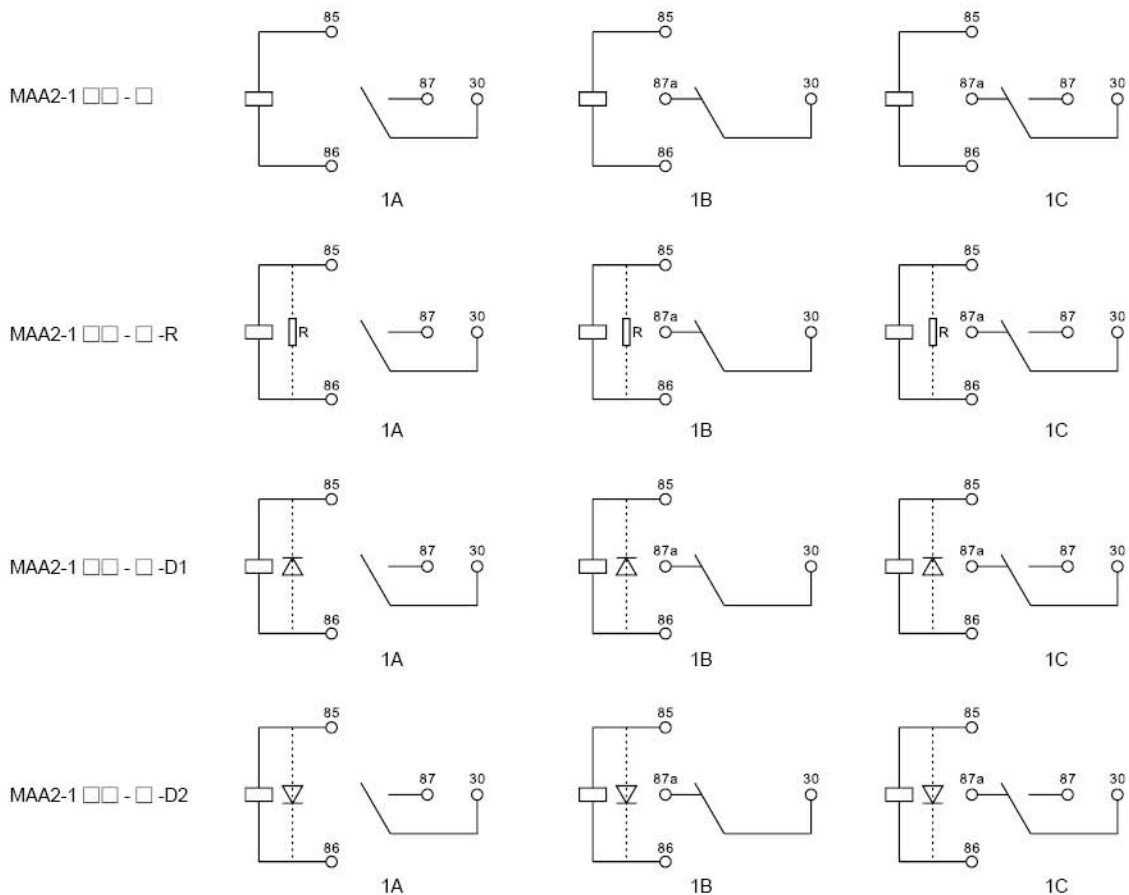

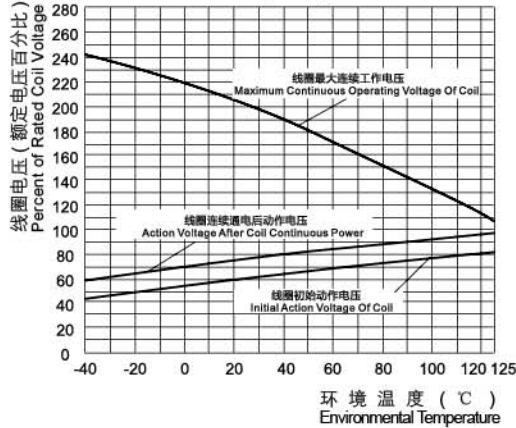
性能曲线图 PERFORMANCE CURVE
1. 线圈连续通电电压范围
Coil Continuous Voltage Range

说明:

- (1) 动作电压与线圈预通电电压有关, 预通电后检查动作电压, 其值会变大
- (2) 线圈最大允许温度为 180℃, 考虑到电阻法所测量的线圈温升是平均值, 推荐在不同使用环境、不同线圈电压、不同负载条件下测量时, 线圈温度应小于 170℃。
- (3) 当线圈实际工作电压超出曲线规定范围时, 请联系美硕并提供相应详细使用条件。

- (1) The operating voltage is connected with coil pre-energized time and voltage. After pre-energized, the operating voltage will increase.
- (2) The maximum allowable coil temperature is 180℃. For the coil temperature rise which is measured by resistance is average value, we recommend the coil temperature should be below 170℃ under the different application ambient, different coil voltage and different load etc.
- (3) If the actual operating coil voltage is out of the specified range please contact meishuo for further details.

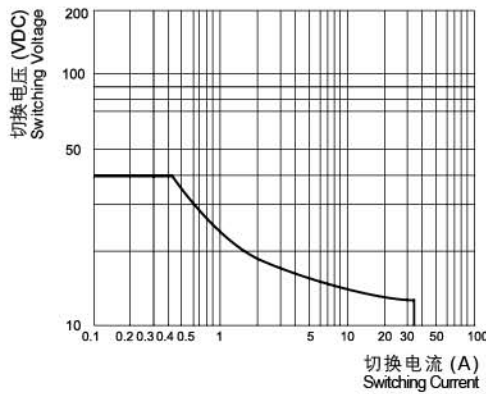
2. 允许最大负载范围
Maximum Load Range

说明:

产品按触点参数表进行负载与耐久性试验, 当实际使用的负载电压、电流、动作频率任一项与触点参数表不同时, 请重新进行确认试验。

The load and electrical endurance tests are made according to "CONTACT DATA" parameters' table. If actual load voltage, current, or operate frequency is different from "CONTACT DATA" table, please arrange corresponding tests for confirmation.

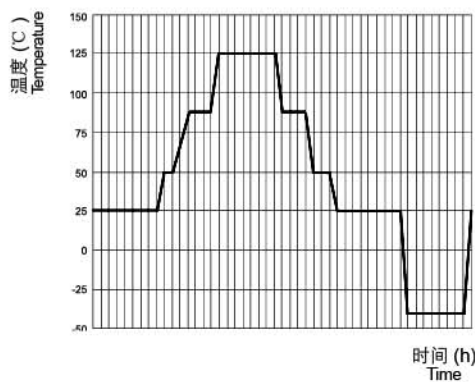
3. 电耐久试验环境温度 a 曲线
Ambient Temperature Curve of the Electrical Endurance Test

说明:

- (1) 最低温度为 -40℃
- (2) 最高温度为 125℃

- (1) The minimum temperature is -40℃.
- (2) The maximum temperature is 125℃.

声明 STATEMENT:

本产品规格书仅供客户使用时参考, 若有更改, 恕不另行通知。

客户应根据具体的使用条件选择与之相匹配的产品。如有疑问, 请与美硕联系获取更多的技术支持, 但产品选型责任由客户承担。

This product specification is for reference only to customers, subject to change without notice.

The customer should select the matching product according to the use condition. Any questions, please feel free contact us to get more technical support. However, product selection responsibility only by the customer.